

MPC
ELECTRONICS

MPC
ELECTRONICS

MPC
ELECTRONICS

MPC
ELECTRONICS

MPC
ELECTRONICS

MPC
ELECTRONICS

MPC
ELECTRONICS

MPC
ELECTRONICS

MPC
ELECTRONICS

MPC
ELECTRONICS

MPC
ELECTRONICS

MPC
ELECTRONICS

MPC
ELECTRONICS

MPC ELECTRONICS LTD
The Gables, Station Road
Willingham
Cambridge CB4 5HG
England
Telephone: Willingham (0954) 60264 (24hr)

MPC
ELECTRONICS

© 1983 MPC Electronics Limited

GENERAL INFORMATION

Rubber Sleeves

Playing the M.P.C. with sticks produces a click as the stick strikes the pad, if you find this distracting then place the rubber sleeves provided over the stick tips.

User Options

To be able to use the full capacity of the M.P.C. the addition of a ZX81/Timex 1000 computer and 16K Rampack is required, this will give you 26 bars/measures, 25 sequences and 25 songs.

With just the computer and the interface you will have the availability of 26 bars/measures, 9 sequences and 9 songs.

Cassette

The cassette provided has 25 songs one side and 9 songs the other side. These can only be loaded into the following combinations:-

25 songs	Computer + Interface + 16K Rampack.
9 songs	Computer + Interface.

Interface

The Interface unit provided is designed only for use with the ZX81/Timex 1000 computer, it contains the program for the system and sufficient memory for 9 sequences and songs.

N.B. This memory will lose its information if the computer is disconnected from its supply. So to retain rhythms either "SAVE" them on cassette or "DOWNLOAD" them to the M.P.C.

This Interface has been designed to mount securely on the back of the ZX81/Sinclair 1000, for permanent fixture use the two white adhesive pads provided. To prevent Rampack wobble use the two black adhesive pads provided on the back of the case.

On/Off

The unit has no on/off switch, it is on immediately the supply is connected.

Pads

It is not necessary to hit the pads very hard, the M.P.C. has been designed for optimum response to allow entry of rhythms with a fairly light touch without breakthrough between pads. However breakthrough may occur if the pads are hit really hard.

Future Advances

Our system is constantly under development. To find new and additional facilities to further expand the usefulness of the M.P.C. we have designed the unit in such a way that future facilities can be added merely by the replacement of one "CHIP" inside the machine.

We therefore suggest you keep in touch with M.P.C. Electronics Ltd. for information as to the availability of these facilities.

Index	Page No.
SOUND GENERATOR CONTROL SECTION	4
TOM TOMS 1 2 3 & 4	4
CLAP	4
CYMBAL	4
HI-HAT	4
BASS DRUM	4
SNARE DRUM	5
H.PHONES	5
MIX OUT	5
GENERAL	5
PAD LAYOUT	5
M.P.C. OUTPUT CONNECTIONS	6
INTERNAL MEMORY	7
GROUP RECORD	7
GROUP PLAY	8
BAR (measure) CONSTRUCTION	8
SEQUENCE RECORD	8
SEQUENCE PLAY	9
PAUSE	9
RUN / STOP FOOTSWITCH	9 & 11
ALTERNATIVE BAR LENGTHS	9
ALTERNATIVE METRONOME BEAT POSITIONS	9
PLAYBACK OF DOWNLOAD SONGS	10
EXTERNAL SYNC	10
USE OF ALTERNATIVE B/M	11
EXTERNAL COMPUTER LINK UP INDEX	12
SPECIFICATIONS	30
"D" CONNECTOR PIN-OUT	31

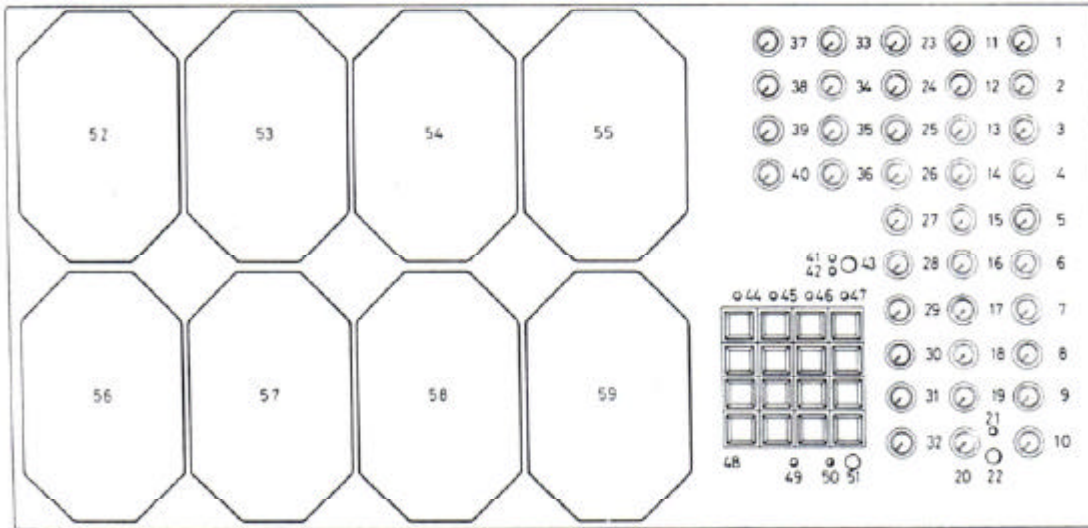
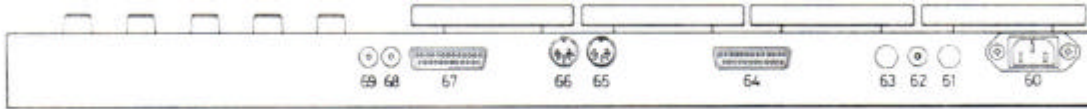

Music Percussion Computer Control Layout

No.	Function	No.	Function
1 - 9	Drum sound level controls.	43	Pad select push button.
10	Master mix-output level.	44 - 47	Keypad indicator L.E.D.'s.
11 - 14	Tom tom decay controls.	48	Keypad.
15	Tom tom skin noise decay.	49 & 50	Playback select L.E.D.'s.
16 - 19	Cymbal, Hi-hat, Bass & Snare decay.	51	Playback select push button.
20	Headphone level.	52 - 59	Live playing pads.
21	Output active L.E.D.	60	Mains inlet socket.
22	Output mute switch.	61 & 63	Tape sync jack sockets.
23 - 26	Tom-tom pitch controls.	62	Run/stop foot switch.
27	Tom-tom skin noise pitch.	64	Computer connection socket.
28	Cymbal/Hi-hat pitch.	65 - 66	D.I.N. external sync sockets.
29	Cymbal/Hi-hat tone.	67	Stage pad socket.
30	Bass drum pitch.	68	Pad select foot switch.
31	Snare drum pitch.	69	Bass pedal socket.
32	Snare noise level.	70 - 78	Individual sound direct output sockets.
33 - 36	Tom-tom tone/noise mix controls.	79	Mix-output socket (stereo).
37 - 40	Tom-tom bend controls.	80	Headphone socket (stereo).
41 & 42	Pad select L.E.D.'s.		

Music Percussion Computer Operating Instructions

Sound Generator Control Section

Tom Tom's 1, 2, 3 & 4

5 controls for each tom-tom. These are as follows:-

- Level - Sets the relative volume of each drum in the mix (1 - 4).
- Decay - Sets the length of decay of the drum tone (11 - 14).
- Pitch - Adjusts the tuning of each drum. The range of tuning is different for each tom-tom, tom 1 being highest through to tom 4 the lowest (23 - 26).
- Bend - Adjust the amount by which the drums pitch is increased upon initial strike of the pad (37 - 40).
- Mix - This blends together the tone of the drum and a skin noise effect, the tone of this skin noise effect is different for each of the four tom-toms (33 - 36) with the overall effect being adjustable in pitch (27) and decay (15).

Clap

Only one control for the handclap volume (5).

Cymbal

- Level - Sets the volume of the cymbal in the mix (6).
- Decay - Sets the length of decay of the cymbal sound (16).
- Pitch - Adjusts the pitch of the cymbal giving the effect of different sized cymbals. i.e. Lower pitch = bigger cymbal (28).
- N.B. This also adjusts the pitch of the hi-hats.
- Tone - Varies the timbre of the cymbal tone to give effects similar to crash or ride cymbals (29).
- N.B. This also adjusts the tone of the Hi-hats.

Hi-hat

- Level - Sets the volume of the hi-hat in the mix (7).
- Tightn - This control acts as a hi-hat tightness control (17) i.e. Fully anti-clockwise simulates hi-hat with the foot hard down on the pedal, gradually advancing the control is like relaxing the pressure of the foot on the hi-hat pedal, while fully clockwise allows the hi-hats to be used as two other cymbals with short and medium length decays.

Bass Drum

- Level - Sets the volume of the bass drum in the mix (8).
- Decay - Sets the length of decay of the bass drum tone (18).
- Pitch - Adjusts the tuning of the bass drum (30).

Snare Drum

- Level - Sets the volume of the snare drum in the mix (9).
- Decay - Adjusts the decay of the snare drum tone (19).
- Noise - Adjusts the level of the noise signal producing the snare sound on the snare drum (32).

Headphone Level (20)

Sets the level of the headphone output (stereo).

Mix Out (10)

Sets the level for the output, this may be muted with the output mute push button (22) with the L.E.D. above it being lit when the output is on.

- N.B. The mix output is in stereo with the sounds of the drums panned in a stereo image to simulate the layout of a normal set of drums.
- For mono amplification use a stereo jack plug with the tip and ring wired together for the signal, otherwise only half the output sound will be amplified.

General

Each of the 9 available sounds has its own individual output socket (sockets 70 - 78) to allow for separate E.Q. or effects to be added to any one or combination of sounds.

- N.B. These sockets do not eliminate the sound from the main mix, if this is required then that particular level control should be turned down. (This is recommended anyway to eliminate any possible "Bleed through" of other sounds to the individual outputs).

Pad Layout

The bottom row of four pads are from left to right:-
Snare drum, Bass drum, Closed Hi-hat, Open Hi-hat

The top row of pads have a push button (43) to select between:-
Tom-tom 1, Tom-tom 2, Tom-tom 3, Tom-tom 4
(L.E.D. 41 lit)

or:- Tom-tom 3, Tom-tom 4, Cymbal, Clap/Accent
(L.E.D. 42 lit)

The second combination is the one to use when recording the drums as Tom tom 1 and Tom tom 2 are play only. i.e. They do not record.

Cymbal / Clap Switch

Push button 51 selects between cymbal (L.E.D. 49) and clap (L.E.D. 50) on playback. i.e. Any beats recorded by playing the cymbal pad in the record mode can be played back as either cymbal or clap.

M.P.C. OUTPUT CONNECTIONS

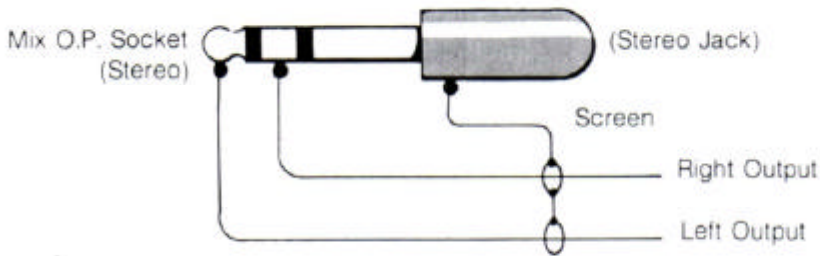

Hi-Fi Connection

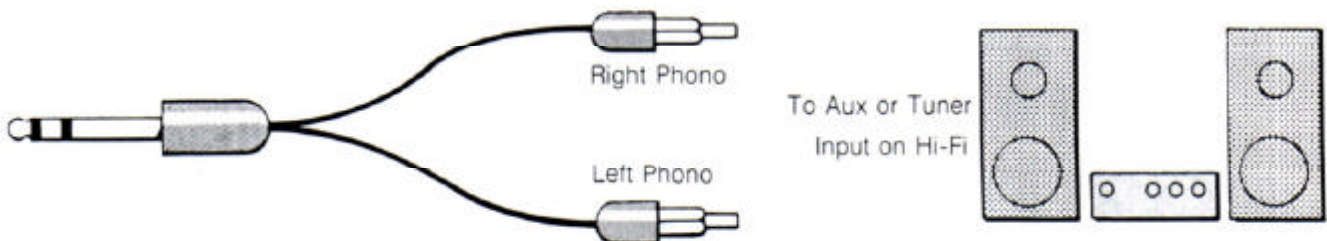

Stereo P.A. Connection

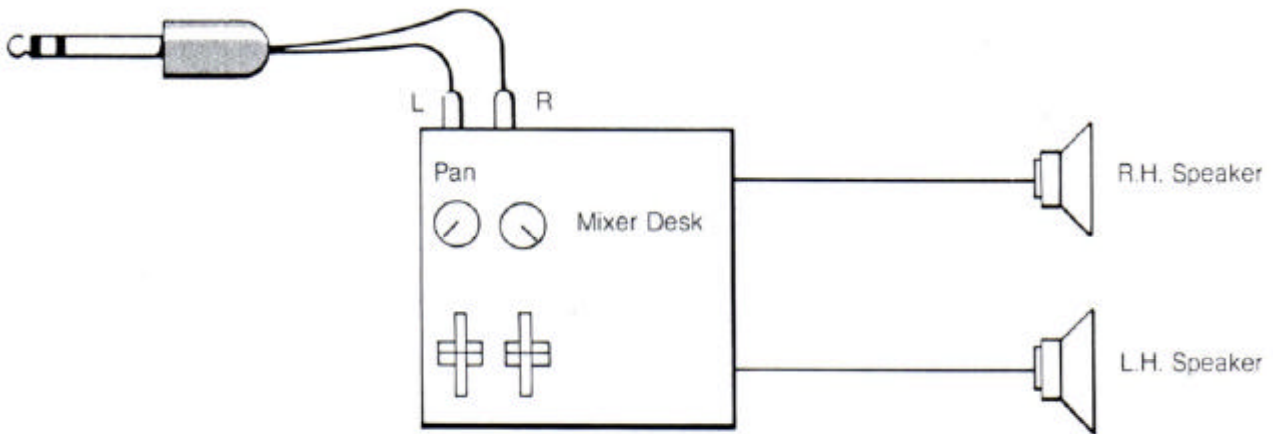

Mono Amplifier

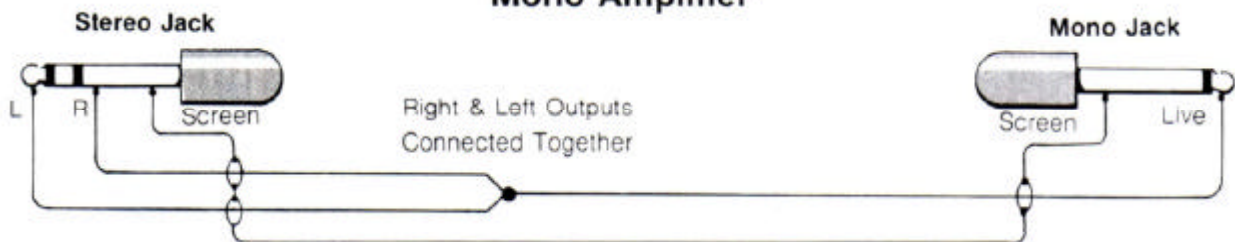

Internal Memory

The M.P.C. has its own internal computer providing a wide range of playing and recording facilities, to use this effectively please study the following operating instructions carefully.

The internal memory is backed up with a battery that is recharged every time the M.P.C. is plugged into the supply, the battery should be able to maintain the memory for up to two years from only one recharging. So once recorded your rhythms will not be lost when the power to the Kit is disconnected.

Firstly the most useful thing to remember is if ever you get confused, i.e. you've pressed the wrong keys or you don't remember which ones you have pressed you can always get out of any condition by pressing "STOP".

IF IN DOUBT - PRESS "STOP".

Group Record

The M.P.C. has 4 groups of two bars (measures) each that you can record rhythms into. i.e.

- Group 1 - Two bars (2 measures)
- Group 2 - Two bars (2 measures)
- Group 3 - Two bars (2 measures)
- Group 4 - Two bars (2 measures)

The rhythm's are recorded in real time by actually playing them on the pads provided, these may be built up a drum at a time or played as one complete rhythm.

To record into the internal groups you must adopt the following procedure.

- (a) Set the "PAD SELECT" to give you Tom 3, Tom 4, cymbal and clap.
 - (b) Press record and all four L.E.D.'s will flash together with a "Metronome" output on the closed Hi-hat.
 - (c) Select the group you wish to record into by pressing "1" on the keypad, now the L.E.D. above key "1" will flash in time with the closed Hi-hat. All four L.E.D.'s flash together to indicate the first beat of the first of the two bars with the metronome output giving four beats to the bar.
 - (d) Start playing from the beat that coincides with all four L.E.D.'s being on. You may play one drum at a time to gradually build up a rhythm and whatever you play will be played back as the computer cycles round its two bar sequence.
Drums may be added indefinitely until the required rhythm is achieved.
- N.B. Accent is written in by using the "CLAP" pad, i.e. Tap this where you want the rhythm accented.

- (e) Once a rhythm has been put into group "1" you may continue putting rhythms into groups 2, 3 & 4 in any order you desire merely by pressing the required group number key and repeating the procedure from (c). The computer will automatically change to the selected group at the end of the two bar cycle during which the new group was selected.
- (f) Should you make a mistake while playing, the group currently being programmed may be cleared by pressing "CLEAR" (while still in the record mode) this will instantly erase all drums from that group ready for another rhythm to be played in.
- (g) Press "STOP" when rhythm programming is complete, this returns the computer to its idle state awaiting further instructions.

Group Play

- (a) Press "PLAY" to replay groups 1 to 4, all four L.E.D.'s flash at a rate of 4 times per bar, this condition allows speed adjustment to be made ("FAST" & "SLOW" keys) before the sounds are activated.
N.B. "FAST" & "SLOW" may be used at any time during either record or play.
- (b) Press group "1" key and group "1" will immediately start playing (the metronome beat is only present during record mode) and will continue to play until another group is selected. Select group "2", group "2" will start playing at the end of the two bar cycle during which the new group was selected.
- (c) Replay in this manner allows groups 1 to 4 to have suitable rhythms for different parts of a song, these can be manually selected and will change from one to the next as and when required without losing the tempo or continuity of the song.
- (d) Modification to a rhythm may be performed at any time by going back into record mode and selecting the group to be modified, this will then replay and can be added to as required.
Groups are only erased when the "clear" key is pressed while in the record mode, and then only the selected group is erased. In this way accidental erasure is unlikely to occur.

Bar (measure) Construction

Each group contains two bars or measures of rhythm, each bar is divided into sixteen divisions, each one of these sixteen divisions or beats may have any number of sounds programmed into it, this form of division allows a very large variety of rhythms to be programmed.

There is however certain rhythms that will not fit i.e. 3/4 time or anything using triplets. It will be explained later how these can be coped with.

Sequence Record

Recorded groups may be arranged into a sequence of up to 199 events so that they may be replayed and automatically change from one group to another.

- (a) Press "SEQ" and the L.E.D.'s flash one at a time in sequence, press "REC" and all L.E.D.'s momentarily light up.
- (b) You may now press the group 1 to 4 keys in any order you choose to write in a sequence of up to 199 changes. Each time you press keys 1 to 4 the L.E.D. above it will light to show it has been entered.
- (c) The sequence can be made to infinitely repeat itself by pressing "0" after your last entry this will return the computer to its idle state ready for play.
- (d) By pressing "STOP" after your last entry the sequence will stop upon completion of the changes entered.

Sequence Play

- (a) Press "SEQ".
- (b) Press "PLAY" and the four L.E.D.'s will flash at the tempo currently set. This may be changed before outputting any sound.
- (c) Press any of the four group keys to start the sequence playing.

Pause

The pause key operates in any mode, press once to pause, press again to continue from the point at which you paused.

Run/Stop Foot Switch

The operation of the pause key is duplicated by the run stop foot switch.

Alternative Bar Lengths

Alternative bar lengths may be used other than the initial 2 bars of 16 beats, choose a different bar length in the following manner:-

- (a) Press "REC" all four L.E.D.'s flash.
 - (b) Press "B" and L.E.D. number "1" will momentarily light.
 - (c) Choose your bar length by pressing keys 1, 2, 3 or 4.
 - Key 1 = 2 bars of 16 beats.
 - Key 2 = 2 bars of 12 beats.
 - Key 3 = 3 bars of 12 beats.
 - Key 4 = 3 bars of 16 beats.
 - (d) Having selected your bar length all four L.E.D.'s start flashing again, you may now choose which group (i.e. 1 to 4) you are going to record into and the bar length for that group will be remembered.
 - (e) You may now move to another group by pressing another group number key and continue recording into this with the same bar length or you may press "B" again and choose a different bar length for the next group to be recorded.
- N.B. The bar length will remain as you have selected it, until you either change it or the units supply is disconnected.

Alternative Metronome Beat Positions

The metronome output used in the record mode may be altered to suit various applications of the above bar lengths. Change this in the following way.

- (a) While in the record mode press "M" and L.E.D. "1" will momentarily light.
 - (b) Choose your metronome beat position by pressing keys 1, 2, 3 or 4.
 - Key 1 = Metronome on the first of each group of 4 beats (i.e. 4 to the bar for 16 beat bars).
 - Key 2 = First of each group of 3 beats.
 - Key 3 = First of each group of 6 beats.
 - Key 4 = First of each group of 8 beats.
 - (c) Having selected your metronome position all four L.E.D.'s start flashing ready for you to choose a group number for recording.
 - (d) The metronome will remain in the chosen position unless you change it. (Even if you go into play and then back into record again).
- N.B. The usefulness of the bar sizes and metronome positions is shown and described at the end of this section.

Playback of Downloaded Songs

Playback of up to 25 songs downloaded from the ZX81 / Timex 1000 can be carried out from the M.P.C. keypad in the following way.

- (a) Press "SHIFT" the L.E.D.'s cycle round with two illuminated at any one time. (This indicates shifted mode).
- (b) Select the song number you wish to play (i.e. 1 to 25) using the numbered keys on the keypad. Successful entry of any number key depression is shown by the L.E.D.'s momentarily shifting to the left hand two and freezing before continuing to cycle.
- (c) Press play and all four L.E.D.'s will flash if there is in fact a song loaded in that memory position, if there is not or if you have selected a song beyond 25 then the L.E.D.'s will extinguish.
- (d) Press any of the group 1 to 4 keys to start the song playing.
- (e) "Fast" and "Slow" may be used to adjust the songs tempo but if you wish to return to the tempo that the song was originally assigned then after pressing "SHIFT" press "B" before selecting the song number.

External Sync.

There are two external sync facilities provided on the M.P.C. these are:-

- (a) The 5 pin din sockets marked "sync in" and "sync out", these may be used for linking between two M.P.C. units (or more) or for connection to other manufacturers equipment. i.e. Roland Bassline, Drumatix etc.
- (b) The tape sync facility, where a sync track may be recorded on one track of a tape recorder from the "To Tape" socket, the M.P.C. will then start and keep in sync with the tape when it is played back into the "From Tape" socket.

Both these facilities work simultaneously so other units can also be driven from the tape track via the M.P.C. through the 5 pin din "Sync out" socket. Also two M.P.C. units may be linked together by the tape sync sockets. i.e. Link "To Tape" on the master unit to "From Tape" on the slave unit.

To select "External sync" use the following procedure:-

Playing Groups

- (a) Press "PLAY" all L.E.D.'s flash.
- (b) Press "SYNC" all L.E.D.'s extinguish.
- (c) Press group number key you wish to play.

Play will commence with external sync input (tape or din) with the speed of play determined by the rate of the clock input.

Playing Sequence

- (a) Press "SEQ" L.E.D.'s flash in sequence.
- (b) Press "PLAY" all L.E.D.'s flash.
- (c) Press "SYNC" all L.E.D.'s extinguish.
- (d) Press any of the group 1 to 4 keys.

Play will commence with external sync input.

Playing Downloaded Songs

- (a) Press "SHIFT" L.E.D.'s flash in sequence.
- (b) Press song number keys.
- (c) Press "PLAY" all L.E.D.'s flash.
- (d) Press "SYNC" all L.E.D.'s extinguish.
- (e) Press any of the group 1 to 4 keys.

Play will commence with external sync input.

Starting Rhythm via Run/Stop Foot Switch

This is very similar to using external sync and for playing groups, sequences or songs follow the "external sync" instructions and replace:-

with:- Press "sync" all L.E.D.'s extinguish.
Press "pause" all L.E.D.'s extinguish.

To start the rhythm it is then only necessary to press either the external run/stop foot switch or the pause key.

Use of Alternative Bar Lengths and Metronome Beats

By choosing various combinations of bar length and metronome beats a variety of other types of rhythm and sequence construction can be accommodated. The following examples point out a few of these.

- (1) By using three bars of sixteen beats it is possible to record 12 bar type sequences with a drum fill etc. at the end of the 12th bar i.e. 4 groups of 3 bars = 12 bars.
- (2) By using two bars of 12 beats $3/4$ or $6/8$ time can be accommodated.
- (3) By using two bars of 12 beats with a metronome output on every 3 beats shuffle rhythms can be easily played in.
- (4) By using three bars of 12 beats with a metronome on every 3rd beat, twelve bar shuffle sequences can be accommodated.
- (5) By using two bars of 16 beats with a metronome on every 8th beat, then one group can be considered as one bar of 32 beats (i.e. double the speed).
- (6) By using 3 bars of 16 beats with the metronome on every 6th beat and the speed very fast then one group can be considered as one bar of 48 beats with the hi-hat metronome playing 8 to the bar. This enables semi quaver triplets to be played.

Other combinations are possible although be warned some bar length / metronome beat combinations do not work, think about what you wish to do first.

SPECIFICATIONS

MUSIC PERCUSSION COMPUTER - M.P.C.

Capacity

26 bars/measures.

Measure Length

1 to 20 steps/beats.

25 Sequences

Length - 1 to 64 bars/measures with repeats this number becomes indeterminate.

25 Songs

Length - 1 to 64 sequences, bars or combinations of both.

OUTPUTS

Individual outputs for each sound source.

Impedance - 1K.

Drum level - 5v P.P. (with accent).

Cymbals level - 2v P.P.

Main Mix (Stereo)

Impedance - 1K.

Level - 5v P.P. (Max.).

Headphones (Stereo)

8 - 600 Ω

Sync.

Din connector (to suit CSQ 600, MC4, TR606, TR303, KPR77 etc.).

Pin 1 - run/stop.

Pin 2 - GND.

Pin 3 - Clock.

Tape Sync (Click Track)

Impedance - 1K.

Level - 3v P.P.

Clock

Pin 25 computer "D" socket. Pins 11 & 23 GND.

5v + VE pulses Even M/S ratio.

Rate = 6 pulses / 1/4 note i.e. ♩ = 24 pulses.

INPUTS

Bass drum pedal - phono.

Pad changeover foot switch - phono (momentary make)

Run/stop foot switch - phono (momentary make)

Sync.

DIN connector (As output).

Tape Sync

Level required - min 0.5v p.p.

Stage Pads

25 way "D" plug.
(Links to stage box for pad connection).

Power

240/110V 50/60HZ.
Consumption - 12 watts.

Dimensions

640 × 340 × 168 mm.

Weight

25 lbs. (11.3 Kgs).

“D” CONNECTORS PIN-OUT

Computer “D” Socket

Pin	1 - Input - Accent	14 - Output - Accent
	2 - Input - Open Hi-Hat	15 - Output - Open Hi-Hat
	3 - Input - Closed Hi-Hat	16 - Output - Closed Hi-Hat
	4 - Input - Tom 3	17 - Output - Tom 3
	5 - Input - Tom 4	18 - Output - Tom 4
	6 - Input - Snare	19 - Output - Snare
	7 - Input - Bass	20 - Output - Bass
	8 - Input - Cymbal	21 - Output - Cymbal
	9 - N/C	22 - N/C
	10 - N/C	23 - GND
	11 - GND	24 -
	12 - N/C	25 - Clock Out
	13 - + 5 volts	

All inputs and outputs TTL level + VE edge triggered

Stage Box "D" Plug

Pin 1 - + 5 volts	14 - Pad Select
2 - Tom 2	15 - Footswitch
3 - GND	16 - GND
4 - Tom 1	17 - N/C
5 - Clap	18 - N/C
6 - Cymbal	19 - N/C
7 - Tom 4	20 - N/C
8 - Bass	21 - N/C
9 - Snare	22 - Pad 4 (Tom 4/Clap)
10 - Tom 3	23 - Pad 3 (Tom 3/Cymbal)
11 - Closed Hi-Hat	24 - Pad 2 (Tom 2/Tom 4)
12 - Open Hi-Hat	25 - Pad 1 (Tom 1/Tom 3)
13 - Cymbal Stop	

All inputs to sound generators require -VE pulse.

RHYTHMS TAPE

25 Song Version Side (2)

Song No.	Title	Sequence	Tempo
1	Rock 8s	16 bar sequence	130 BPM
2	Disco	8 bar sequence	120 BPM
3	Shuffle	12 bar sequence	90 BPM
4	Rock 4s	16 bars & 8 bar series	122 BPM
5	12/8 Rhythm	Continuous play	120 BPM
6	Reggae	8 Bar sequence	90 BPM
7	Rock	12 bar changes every 4th sequence	150 BPM
8	Mixed Feel	12/8, shuffle & rock	120 BPM
9	5/4 rhythm	Continuous play	170 BPM
10	Rock & 5/4	Continuous alternative bars	155 BPM
11	Funky	16 bar sequence	120 BPM
12	7/8	Continuous play	120 BPM
13	All bars	Played sequentially	120 BPM
14	Changing Hi-hat rhythms		105 BPM
15	Shuffle 12 bar at normal & double speeds		80 BPM × 2
16	Rock 4s	12 bar	140 BPM
17	Disco	12 bar	110 BPM
18	Mixed rock & disco	12 bars at different tempos	
19	Mixed different feels with odd bars in between		
20	12/8, 7/8 & 5/4	Mixed	138 BPM
21	Funky	16 bar seq. (continuous play)	120 BPM
22	Funky	16 bar seq. (single play)	100 BPM
23	Funky	16 bar seq. (single play)	150 BPM
24	Test bar	Accent test for Hi-tom, low-tom, bass & cymbal	120 BPM
25	Test bar	Hi-hat o/c test, snare accent	120 BPM

RHYTHMS TAPE

9 Song Version Side (1)

Song No.	Title	Length	Tempo
(1)	Rock 8's	16 bar sequence	130 BPM
(2)	Disco	8 bar sequence	120 BPM
(3)	Shuffle	12 bar sequence	90 BPM
(4)	Rock 4's	16 bar & 8 bar series	122 BPM
(5)	12/8 rhythm	Continuous play	120 BPM
(6)	Reggae	8 bar sequence	90 BPM
(7)	Rock	12 bar changes every 4th sequence	150 BPM
(8)	5/4 rhythm	Continuous play	170 BPM
(9)	Funky	16 bar sequence	120 BPM

N.B. Most of the above have been written with an infinite repeat i.e. They will play continuously until "BREAK" or "STOP" is pressed.